

## POMPĂ CENTRIFUGALĂ CM40 – 125B

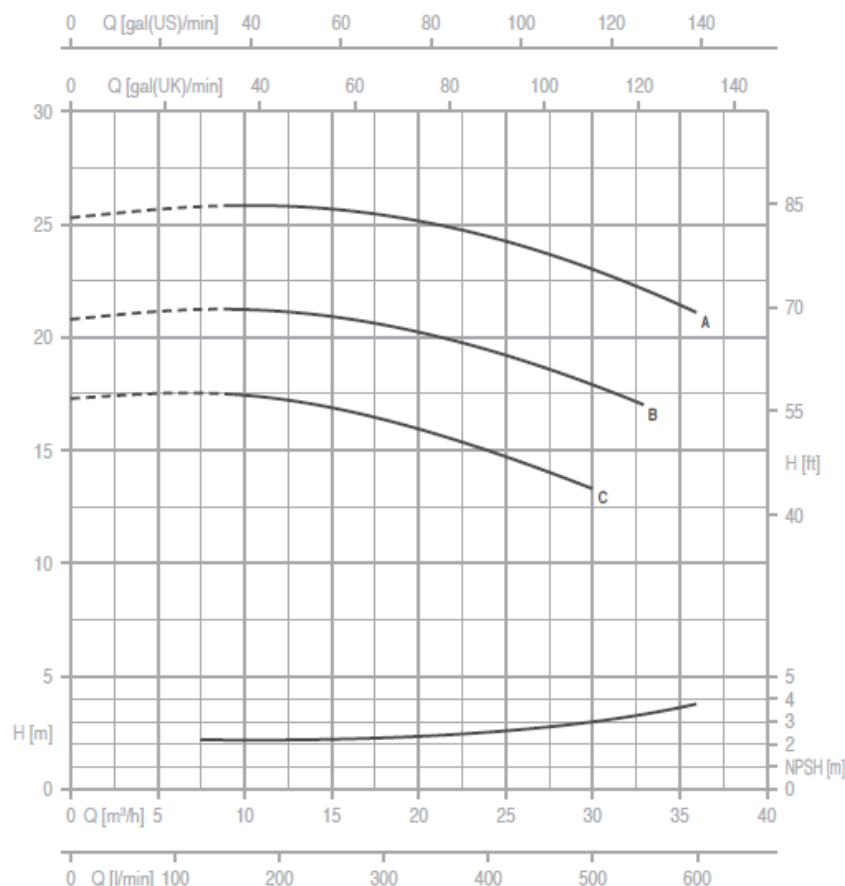

Putere absorbită P1:	2.9 kW
Putere P2:	2.2 kW
Alimentare:	230 V / 400 V (50 Hz)
Inălțime maximă de refulare:	20.7 m
Debit maxim:	33000 l/h
Presiune maximă:	10 bar
Diametru de aspirație:	65 mm
Diametru de refulare:	40 mm



Debit Q (m <sup>3</sup> /h - l/min)										
0	7.5	9	12	15	18	21	24	27	30	33
0	125	150	200	250	300	350	400	450	500	550
Înălțime de refulare H (m)										
20.7	-	21.3	21.2	21	20.6	20.1	19.4	18.7	17.9	17

Temperatura maximă a apei:  
 Carcasă pompă:  
 Suport motor:  
 Rotor pompă:  
 Etanșare mecanică:  
 Arbore motor:  
 Clasă de izolație:  
 Clasă de protecție:  
 Flanșe de cuplare pentru aspirație  
 și refulare

90 °C  
 fontă  
 fontă  
 fontă/bronz/inox  
 ceramică – grafit  
 oțel AISI 316  
 F  
 IP55  
  
 incluse

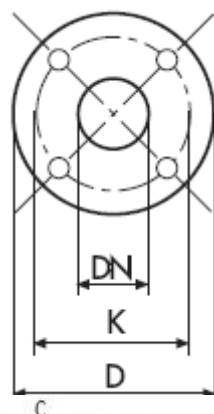

DIMENSIONS (mm)				
DN	D	K	holes	
			n°	ø
32	140	100	4	18
40	150	110	4	18
50	165	125	4	18
65	185	145	4	18
80	200	160	4	18
100	220	180	8	18

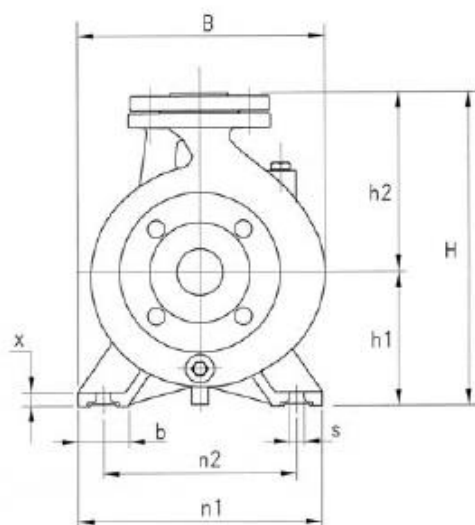
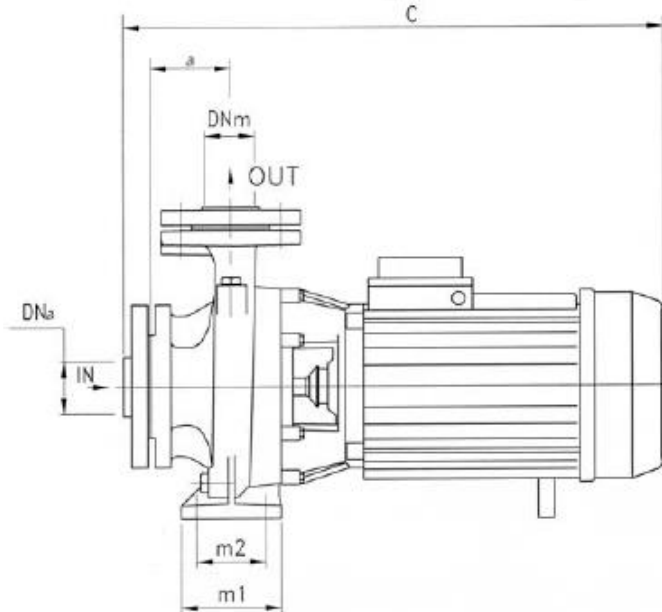

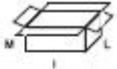
TYPE	DIMENSIONS (mm)																			Kg
	DNm	DNa	a	h1	h2	m1	m2	n1	n2	b	x	s	C	B	H	I	L	M		
CM 32-160 C	32	50	80	132	160	100	70	240	190	50	12	14	490	240	292	520	260	355	38	
CM 32-160 B	32	50	80	132	160	100	70	240	190	50	12	14	490	240	292	520	260	355	39	
CM 32-160 A	32	50	80	132	160	100	70	240	190	50	12	14	490	240	292	520	260	355	42	
CM 32-200 C	32	50	80	160	180	100	70	240	190	50	12	14	505	268	340	530	305	400	51.5	
CM 32-200 B1	32	50	80	160	180	100	70	240	190	50	12	14	520	268	340	615	310	460	61	
CM 32-200 B	32	50	80	160	180	100	70	240	190	50	12	14	565	268	340	615	310	460	63	
CM 32-200 A1	32	50	80	160	180	100	70	240	190	50	12	14	520	268	340	615	310	460	67	
CM 32-200 A	32	50	80	160	180	100	70	240	190	50	12	14	565	268	340	615	310	460	69	
CM 32-250 C	32	50	100	180	225	125	95	320	250	65	12	14	625	305	405	665	335	535	83	
CM 32-250 B	32	50	100	180	225	125	95	320	250	65	14	14	625	305	405	665	335	535	90	
CM 32-250 A1	32	50	100	180	225	125	95	320	250	65	14	14	625	305	405	665	335	535	95	
CM 32-250 A	32	50	100	180	225	125	95	320	250	65	14	14	695	305	405	735	335	535	120	
CM 40-125 C	40	65	80	112	140	100	70	210	160	50	12	14	495	220	252	520	260	355	36	
CM 40-125 B	40	65	80	112	140	100	70	210	160	50	12	14	495	220	252	520	260	355	37	
CM 40-125 A	40	65	80	112	140	100	70	210	160	50	12	14	495	220	252	520	260	355	40	
CM 40-160 B	40	65	80	132	160	100	70	240	190	50	12	14	500	245	292	520	260	355	47	
CM 40-160 A	40	65	80	132	160	100	70	240	190	50	15	14	500	245	292	520	260	355	50	
CM 40-200 B	40	65	100	160	180	100	70	265	212	50	15	14	590	273	340	615	310	460	65	
CM 40-200 A	40	65	100	160	180	100	70	265	212	50	15	14	590	273	340	615	310	460	71	
CM 40-250 C	40	65	100	180	225	125	95	320	250	65	15	14	630	322	405	665	335	535	84	
CM 40-250 B	40	65	100	180	225	125	95	320	250	65	15	14	630	322	405	665	335	535	91	
CM 40-250 A1	40	65	100	180	225	125	95	320	250	65	15	14	630	322	405	665	335	535	96	
CM 40-250 A	40	65	100	180	225	125	95	320	250	65	15	14	700	322	405	735	335	535	121	